

# GENERAL INFORMATION

GI

## SECTION **GI**

### CONTENTS

PRECAUTIONS .....	GI- 2
HOW TO USE THIS MANUAL .....	GI- 5
HOW TO READ WIRING DIAGRAMS .....	GI- 7
HOW TO FOLLOW FLOW CHART IN TROUBLE DIAGNOSES .....	GI-10
IDENTIFICATION INFORMATION .....	GI-13
LIFTING POINTS AND TOW TRUCK TOWING .....	GI-17
TIGHTENING TORQUE OF STANDARD BOLTS .....	GI-20

# FOREWORD

---

This manual contains maintenance and repair procedures for Nissan 200SX, model S13 series.

In order to assure your safety and the efficient functioning of the vehicle, this manual should be read thoroughly. It is especially important that the PRECAUTIONS in the GI section be completely understood before starting any repair task.

All information in this manual is based on the latest product information at the time of publication. The right is reserved to make changes in specifications and methods at any time without notice.

---

## IMPORTANT SAFETY NOTICE

The proper performance of service is essential for both the safety of the technician and the efficient functioning of the vehicle.

The service methods in this Service Manual are described in such a manner that the service may be performed safely and accurately.

Service varies with the procedures used, the skills of the technician and the tools and parts available. Accordingly, anyone using service procedures, tools or parts which are not specifically recommended by NISSAN must first completely satisfy himself that neither his safety nor the vehicle's safety will be jeopardized by the service method selected.



**NISSAN MOTOR CO., LTD.**

Overseas Service Department

Tokyo, Japan

## PRECAUTIONS

Observe the following precautions to ensure safe and proper servicing. These precautions are not described in each individual section.

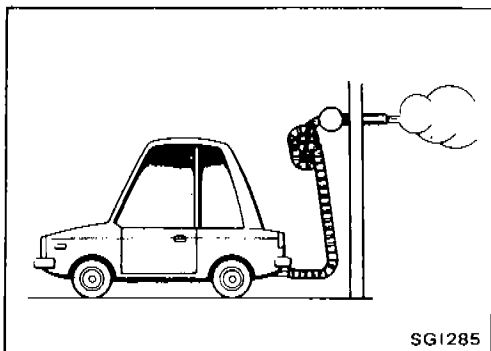

1. Do not operate the engine for an extended period of time without proper exhaust ventilation. Keep the work area well ventilated and free of any inflammable materials. Special care should be taken when handling any inflammable or poisonous materials, such as gasoline, refrigerant gas, etc. When working in a pit or other enclosed area, be sure to properly ventilate the area before working with hazardous materials. Do not smoke while working on the vehicle.

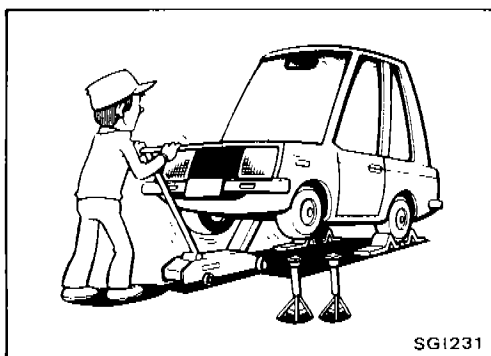

2. Before jacking up the vehicle, apply wheel chocks or other tire blocks to the wheels to prevent the vehicle from moving. After jacking up the vehicle, support the vehicle weight with safety stands at the points designated for proper lifting and towing before working on the vehicle. These operations should be done on a level surface.
3. When removing a heavy component such as the engine or transaxle/transmission, be careful not to lose your balance and drop them. Also, do not allow them to strike adjacent parts, especially the brake tubes and master cylinder.

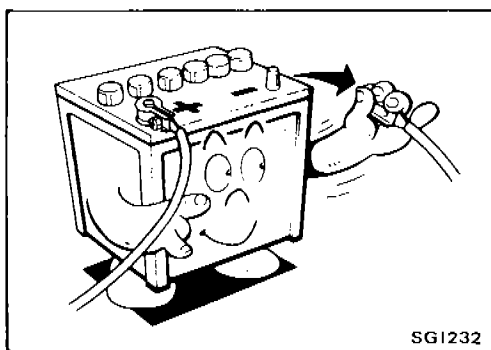

4. Before starting repairs which do not require battery power, always turn off the ignition switch, then disconnect the ground cable from the battery to prevent accidental short circuit.

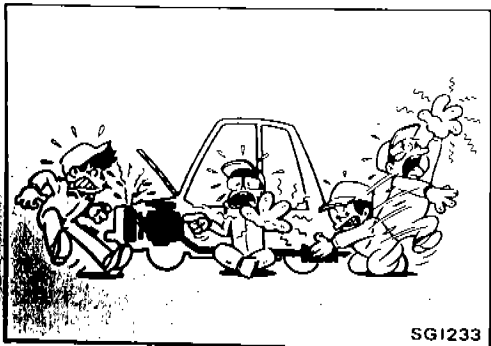

5. To prevent serious burns, avoid contact with hot metal parts such as the radiator, exhaust manifold, tail pipe and muffler. Do not remove the radiator cap when the engine is hot.

## PRECAUTIONS

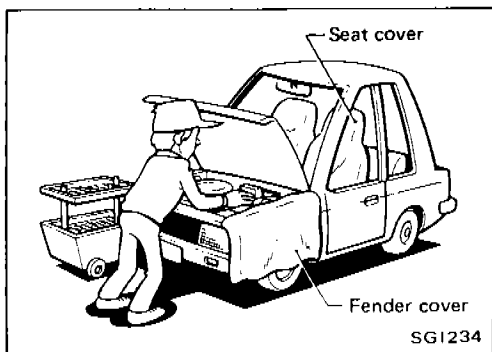

6. Before servicing the vehicle, protect fenders, upholstery and carpeting with appropriate covers. Take caution that keys, buckles or buttons on your person do not scratch the paint.
7. Clean all disassembled parts in the designated liquid or solvent prior to inspection or assembly.
8. Replace oil seals, gaskets, packings, O-rings, locking washers, cotter pins, self-locking nuts, etc. with new ones.
9. Replace inner and outer races of tapered roller bearings and needle bearings as a set.
10. Arrange the disassembled parts in accordance with their assembled locations and sequence.
11. Do not touch the terminals of electrical components which use microcomputers (such as electronic control units). Static electricity may damage internal electronic components.
12. After disconnecting vacuum or air hoses, attach a tag to indicate the proper connection.
13. Use only the lubricants specified in MA section.
14. Use approved bonding agent, sealants or their equivalents when required.
15. Use tools and recommended special tools where specified for safe and efficient service repairs.
16. When repairing the fuel, oil, water, vacuum or exhaust systems, check all affected lines for leaks.
17. Dispose of drained oil or the solvent used for cleaning parts in an appropriate manner.

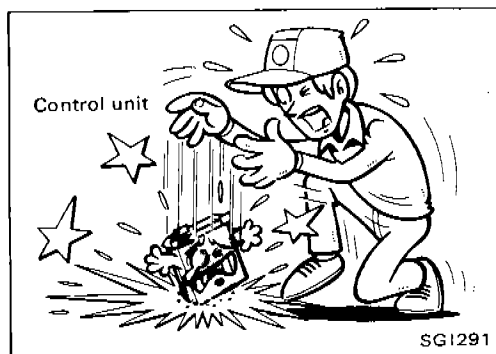

### Precautions for E.F.I. or E.C.C.S. Engine

1. Before connecting or disconnecting E.F.I. or E.C.C.S. harness connector to or from any E.F.I. or E.C.C.S. control unit, be sure to turn the ignition switch to the "OFF" position and disconnect the negative battery terminal. Otherwise, there may be damage to control unit.
2. Before disconnecting pressurized fuel line from fuel pump to injectors, be sure to release fuel pressure to eliminate danger.
3. Be careful not to jar components such as control unit and air flow meter.

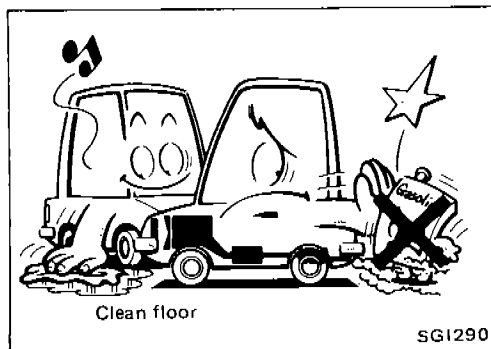

### Precautions for Catalyst

If a large amount of unburned fuel flows into the converter, the converter temperature will be excessively high. To prevent this, follow the procedure below:

1. Use unleaded gasoline only. Leaded gasoline will seriously damage the catalytic converter.
2. When checking for ignition spark or measuring engine compression, make tests quickly and only when necessary.
3. Do not run engine when the fuel tank level is low, otherwise the engine may misfire causing damage to the converter.
4. Do not place the vehicle on inflammable material. Keep inflammable material off the exhaust pipe.

## PRECAUTIONS

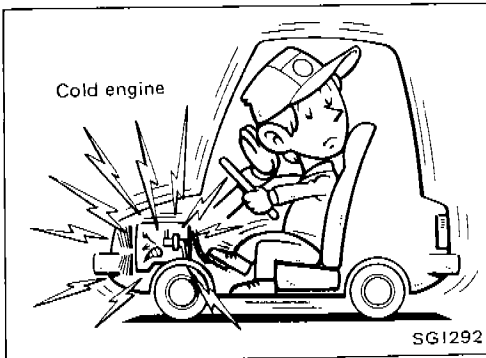

### Precautions for Turbocharger

The turbocharger system uses engine oil for lubrication and cooling of its rotating components. The turbocharger turbine turns at a speed in excess of 100,000 rpm at full throttle and its temperature can reach 870°C (1,600°F). It is essential to maintain a clean supply of oil flowing through the turbocharger system. Therefore, a sudden interruption of oil supply may cause a malfunction in the turbocharger.

For proper operation of the system, follow the procedure below:

1. Always use the recommended oil. Follow the instructions for proper time to change the oil and proper oil level.
2. Avoid accelerating engine to a high rpm immediately after starting.
3. If engine had been operating at high rpm for an extended period of time, let it idle for a few minutes prior to shutting it off.

### Asbestos Safety Instructions

#### (Based on regulations of United Kingdom)

This vehicle uses parts containing asbestos, most are not hazardous but Brake and Clutch linings can be. Consult the manufacturer or his agent for further details. When working with these please observe the "Garage Workers' Asbestos Code" available through your Nissan Dealer, Local Authority or Health and Safety Executive. In particular, work in a well-ventilated place using where possible appropriate dust extraction equipment and avoid creating dust. Dampen all asbestos/dust where possible prior to machining, cutting, cleaning, etc. Use only hand or low speed tools.

Dispose of all asbestos waste, wet rags, etc., in a closed container as directed by your local waste disposal authority.

### Precautions for Fuel

#### EUROPE

**CA18DET with catalytic converter:**

**Unleaded gasoline of at least 95 octane (RON)**

**CA18DET without catalytic converter:**

**Leaded or unleaded gasoline of at least 95 octane (RON)**

#### EXCEPT EUROPE

**Leaded gasoline of at least 95 octane (RON)**

## HOW TO USE THIS MANUAL

1. **A QUICK REFERENCE INDEX**, a black tab (e.g. **BR**) is provided on the first page. You can quickly find the first page of each section by mating it to the section's black tab.
2. **THE CONTENTS** are listed on the first page of each section.
3. **THE TITLE** is indicated on the upper portion of each page and shows the part or system.
4. **THE PAGE NUMBER** of each section consists of two letters which designate the particular section and a number (e.g. "BR-5").
5. **THE LARGE ILLUSTRATIONS** are exploded views (See below) and contain tightening torques, lubrication points and other information necessary to perform repairs. The illustrations should be used in reference to service matters only. When ordering parts, refer to the appropriate **PARTS CATALOG**.

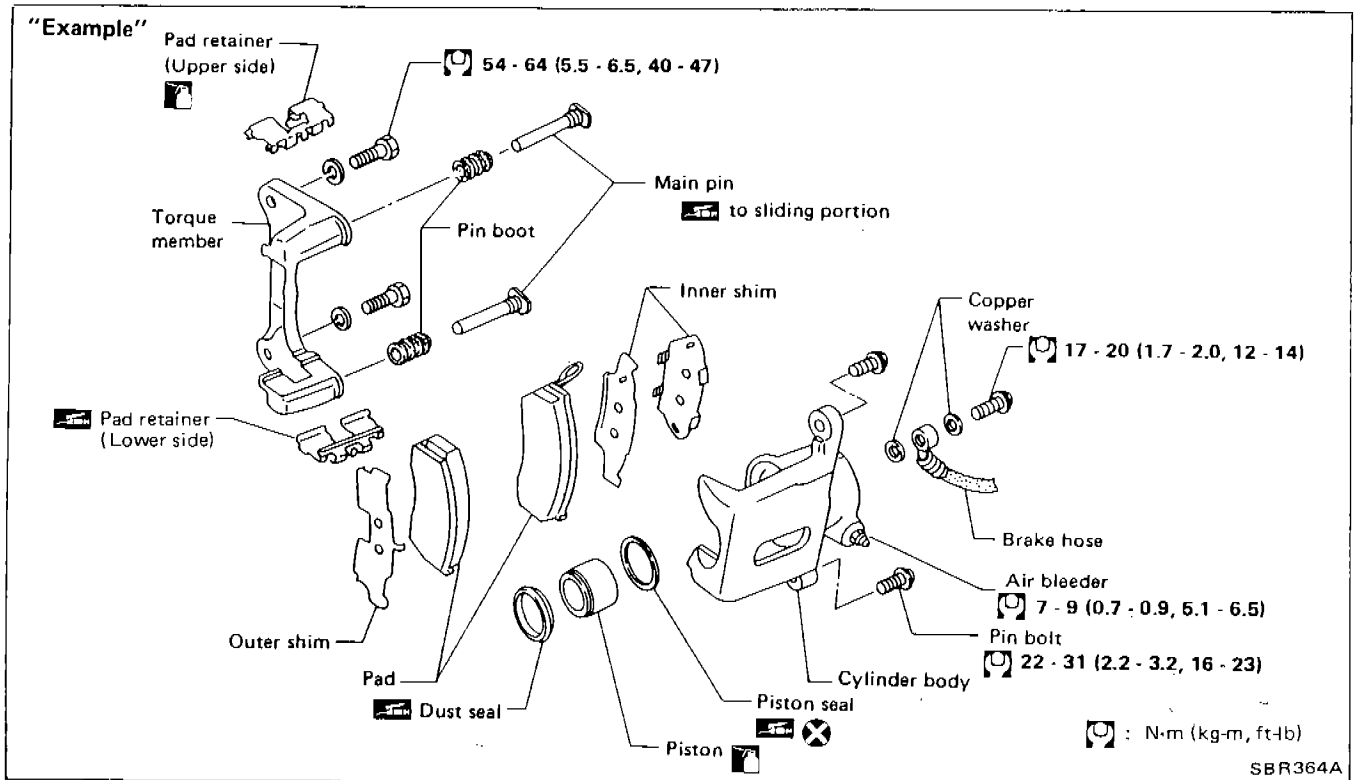

6. **THE SMALL ILLUSTRATIONS** show the important steps such as inspection, use of special tools, knacks of work and hidden or tricky steps which are not shown in the previous large illustrations. Assembly, inspection and adjustment procedures for the complicated units such as the automatic transaxle or transmission, etc. are presented in a step-by-step format where necessary.

7. The following **SYMBOLS AND ABBREVIATIONS** are used:

	: Tightening torque	4WD	: 4-Wheel Drive
	: Should be lubricated with grease. Unless otherwise indicated, use recommended multi-purpose grease.	M/T	: Manual Transaxle/Transmission
	: Should be lubricated with oil.	A/T	: Automatic Transaxle/Transmission
	: Sealing point	A/C	: Air Conditioner
	: Checking point	P/S	: Power Steering
	: Always replace after every disassembly.	S.S.T.	: Special Service Tools
L.H., R.H.	: Left-Hand, Right-Hand	S.D.S.	: Service Data and Specifications
FR, RR	: Front, Rear	SAE	: Society of Automotive Engineers, Inc.
2WD	: 2-Wheel Drive	G.C.C.	: Gulf Cooperation Council
		L.H.D.	: Left-Hand Drive
		R.H.D.	: Right-Hand Drive

## HOW TO USE THIS MANUAL

---

8. The **UNITS** given in this manual are primarily expressed as the SI UNIT (International System of Unit), and alternatively expressed in the metric system and in the yard/pound system.

"Example"

Tightening torque

59 - 78 N·m (6.0 - 8.0 kg-m, 43 - 58 ft-lb)

9. **TROUBLE DIAGNOSES** are included in sections dealing with complicated components.
10. **SERVICE DATA AND SPECIFICATIONS** are contained at the end of each section for quick reference of data.
11. The captions **WARNING** and **CAUTION** warn you of steps that must be followed to prevent personal injury and/or damage to some part of the vehicle.
- **WARNING** indicates the possibility of personal injury if instructions are not followed.
  - **CAUTION** indicates the possibility of component damage if instructions are not followed.
  - **BOLD TYPED STATEMENTS** except **WARNING** and **CAUTION** give you helpful information.

# HOW TO READ WIRING DIAGRAMS

## WIRING DIAGRAM

Symbols used in WIRING DIAGRAM are shown below:

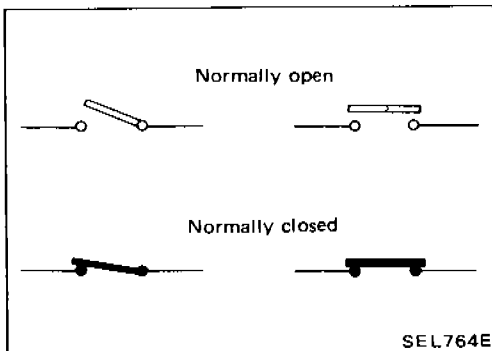
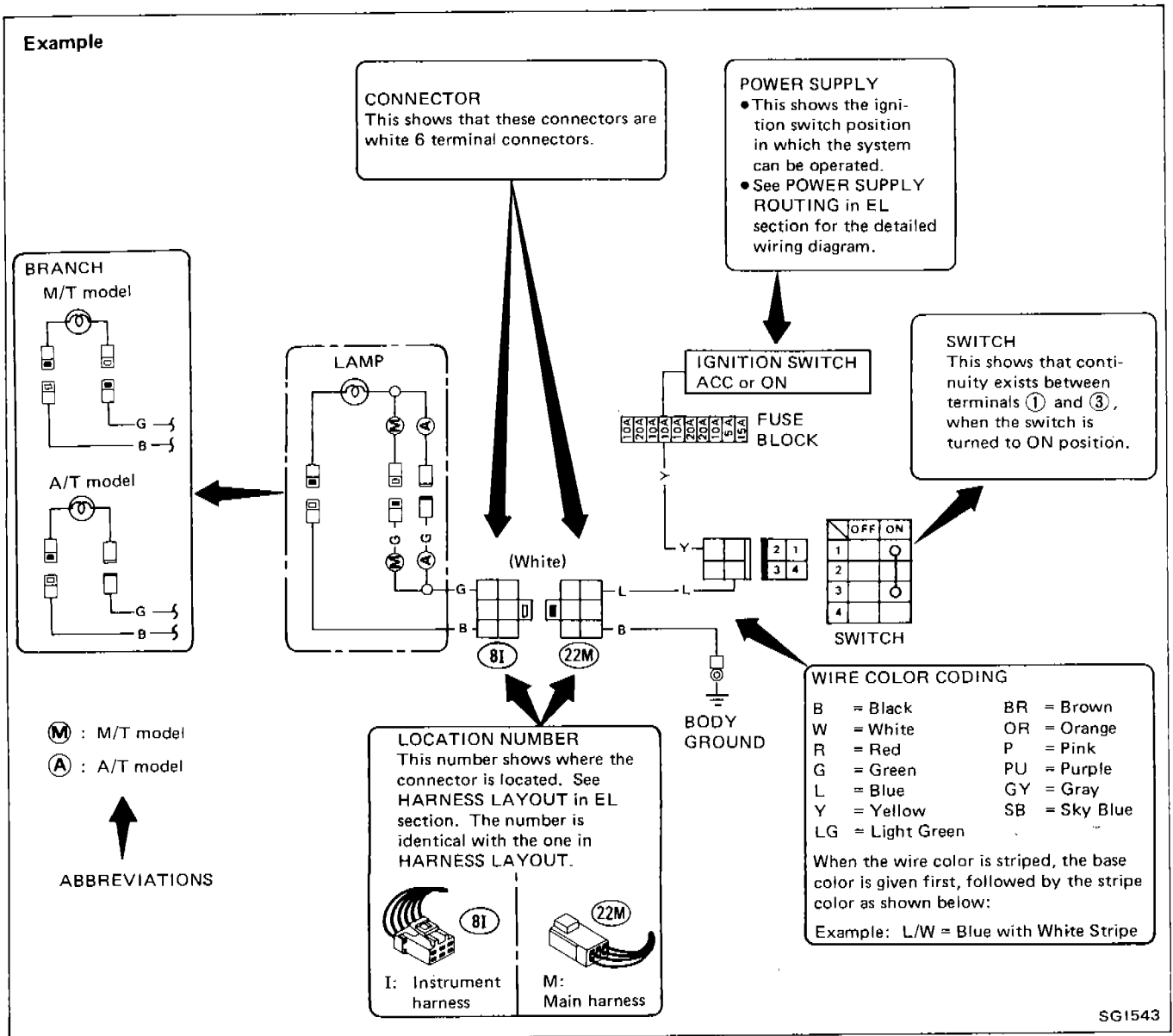

## SWITCH POSITIONS

Wiring diagram switches are shown with the vehicle in the following condition.

- Ignition switch "OFF".
- Doors, hood and trunk lid/back door closed.
- Pedals are not depressed and parking brake is released.



# HOW TO READ WIRING DIAGRAMS

## Example

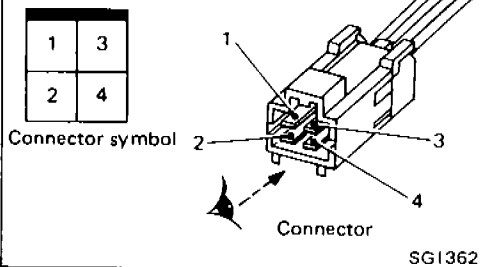

## CONNECTOR SYMBOLS

- All connector symbols in wiring diagrams are shown from the terminal side.

## Example

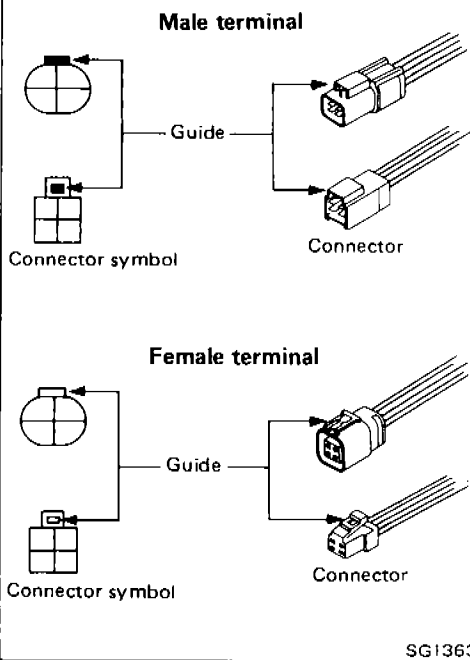

- Male and female terminals  
Connector guides for male terminals are shown in black and female terminals in white in wiring diagrams.

## MULTIPLE SWITCH

The continuity of the multiple switch is identified in the switch chart in wiring diagrams.

## Example

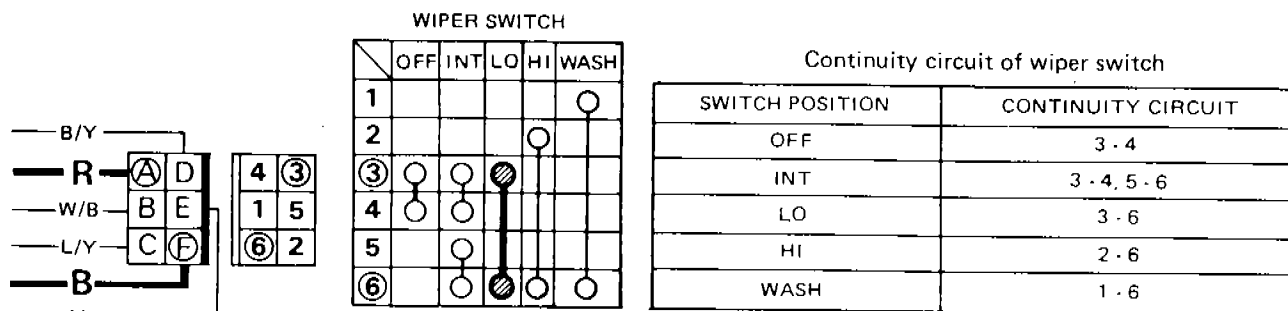

Example: Wiper switch in LO position

Continuity circuit: Red wire - (A) terminal - (3) terminal - Wiper switch (● - ● : LO) - (6) terminal - (F) terminal - Black wire

SGI365

# HOW TO READ WIRING DIAGRAMS

## SUPER MULTIPLE JUNCTION (S.M.J.)

- The "S.M.J." indicated in wiring diagrams is shown in a simplified form. The terminal arrangement should therefore be referred to in the foldout at the end of the Service Manual.
- The foldout should be spread to read the entire wiring diagram.

Example

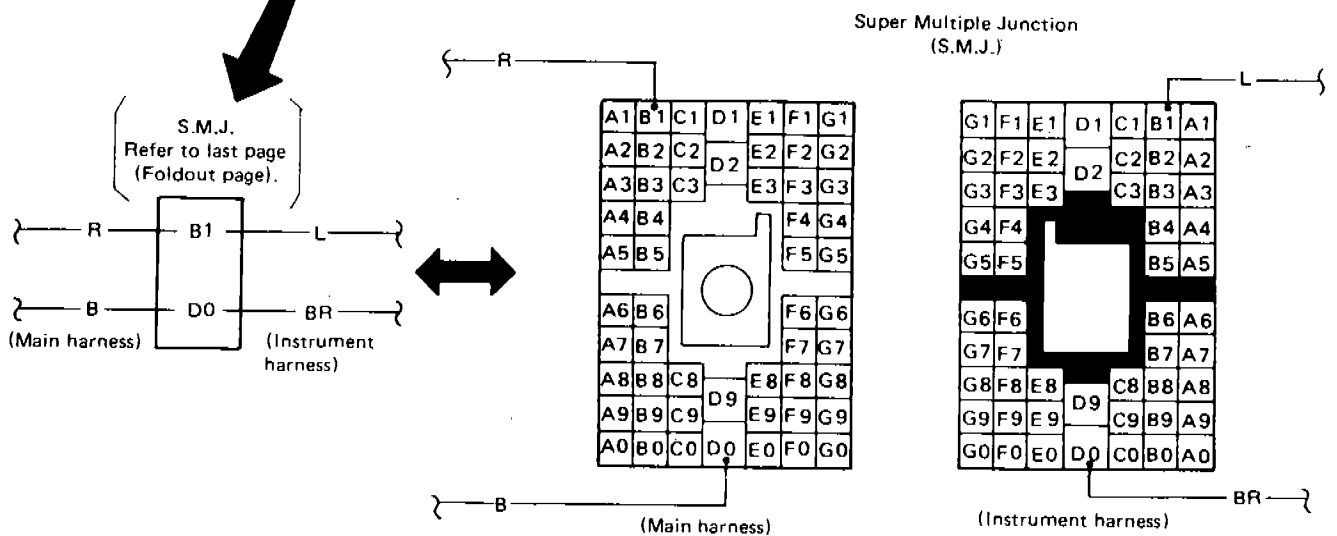
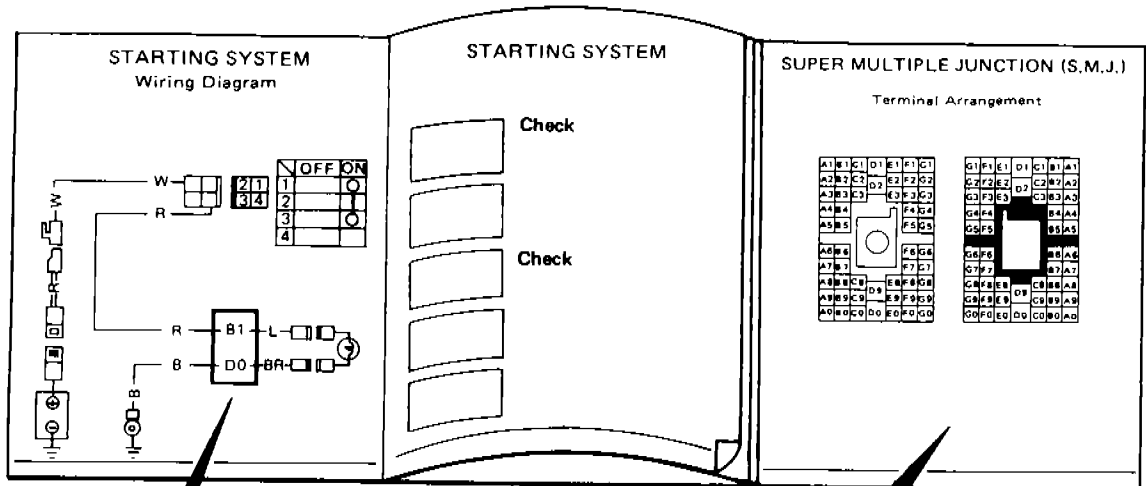

SEL653F

# HOW TO FOLLOW FLOW CHART IN TROUBLE DIAGNOSES

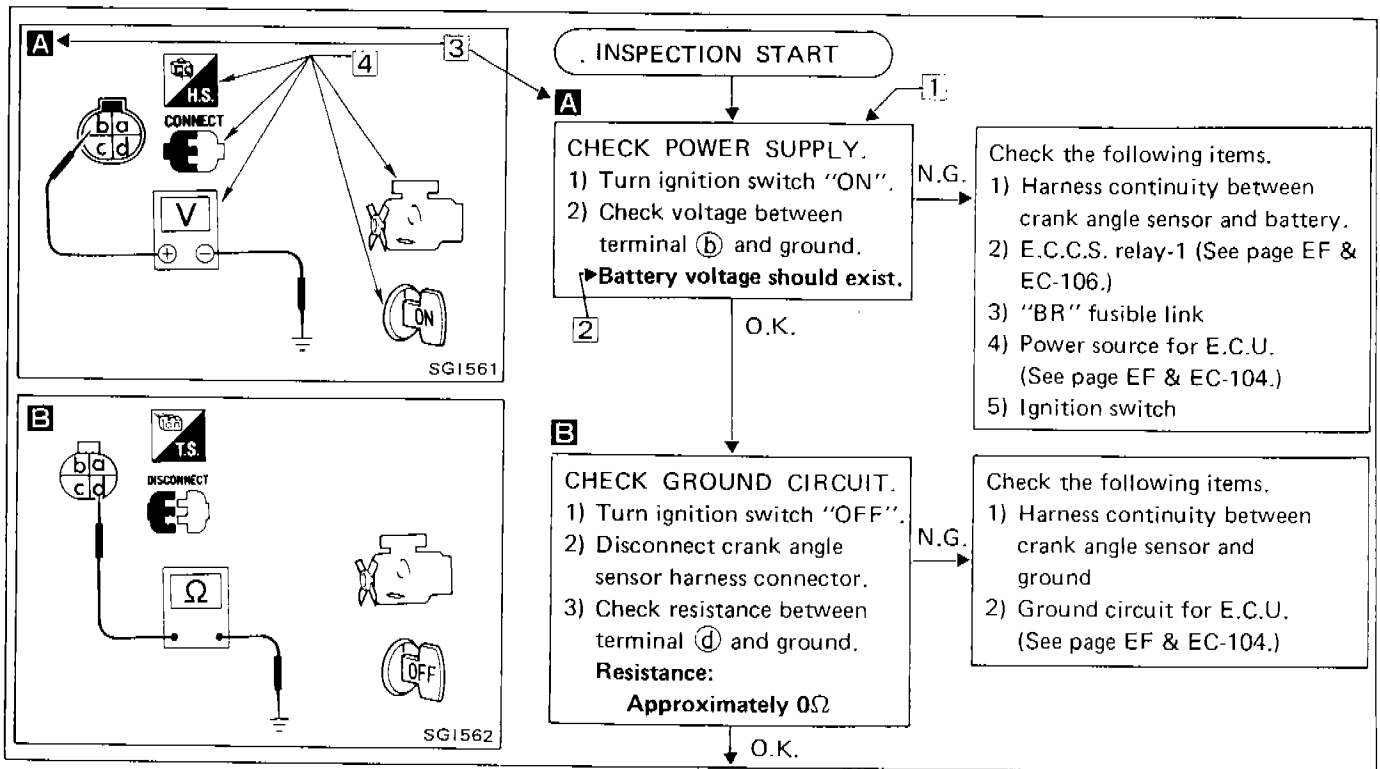

## NOTICE

The flow chart indicates work procedures required to diagnose problems effectively. Observe the following instructions before diagnosing.

- 1) Use the flow chart after locating probable causes of a problem following the "Preliminary Check" or the "Symptom Chart".
- 2) After repairs, recheck that the problem has been completely eliminated.
- 3) Refer to Component Parts Location and Harness Layout for the Systems described in each section for identification/location of components and harness connectors.
- 4) Refer to the Circuit Diagram for Quick Pinpoint Check. If you must perform circuit continuity between harness connectors more detail, such as in case of sub-harness is used, refer to Wiring Diagram and Harness Layout in EL section for identification of harness connectors.
- 5) When checking circuit continuity, ignition switch should be "OFF".
- 6) Before checking voltage at connectors, check battery voltage.
- 7) After accomplishing the Diagnostic Procedures and Electrical Components Inspection, make sure that all harness connectors are reconnected as it was.

## HOW TO FOLLOW THIS FLOW CHART

### 1 Work and diagnostic procedure

Start to diagnose a problem using procedures indicated in enclosed blocks, as shown in the following example.

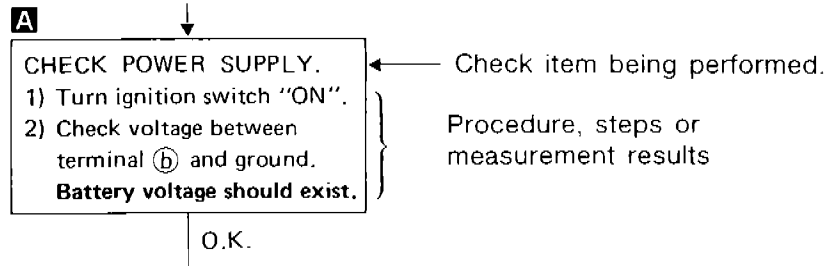

### 2 Measurement results

Required results are indicated in bold type in the corresponding block, as shown below:

These have the following meanings:

**Battery voltage** → 11 - 14V or approximately 12V  
**Voltage:** Approximately 0V → Less than 1V

### 3 Cross reference of work symbols in the text and illustrations

Illustrations are provided as visual aids for work procedures. For example, symbol **A** indicated in the left upper portion of each illustration corresponds with the symbol in the flowchart for easy identification. More precisely, the procedure under the "CHECK POWER SUPPLY." outlined previously is indicated by an illustration **A**.

### 4 Symbols used in illustrations

Symbols included in illustrations refer to measurements or procedures. Before diagnosing a problem, familiarize yourself with each symbol.

#### Direction mark

A direction mark is shown to clarify the side of connector (terminal side or harness side).

Direction marks are mainly used in the illustrations indicating terminal inspection.



: View from terminal side ... T.S.

- All connector symbols shown from the terminal side are enclosed by a single line.







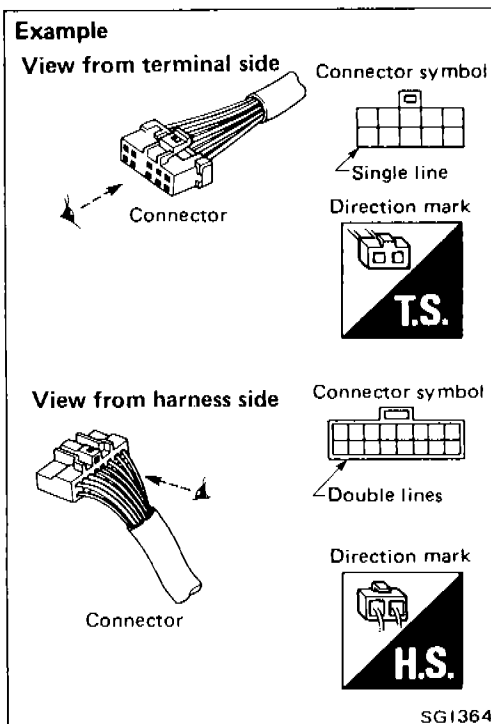

















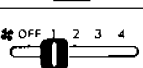

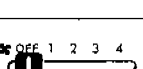







: View from harness side ... H.S.

- All connector symbols shown from the harness side are enclosed by a double line.

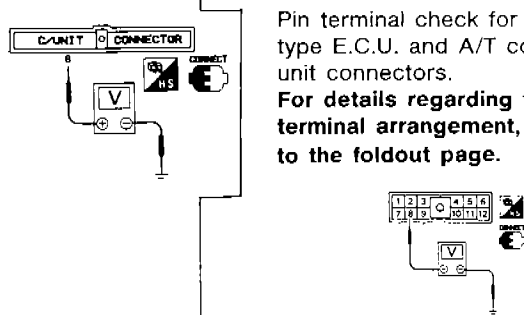

# HOW TO FOLLOW FLOW CHART IN TROUBLE DIAGNOSES

## Key to symbols signifying measurements or procedures

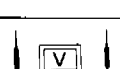
Symbol	Symbol explanation	Symbol	Symbol explanation
	Check after disconnecting the connector to be measured.		A. C switch is "OFF".
	Check after connecting the connector to be measured.		A. C switch is "ON".
	Insert key into ignition switch.		REC switch is "ON".
	Turn ignition switch to "OFF" position.		REC switch is "OFF".
	Turn ignition switch to "ON" position.		DEF switch is "ON".
	Turn ignition switch to "START" position.		VENT switch is "ON".
	Turn ignition switch from "OFF" to "ACC" position.		Fan switch is "ON". (At any position except for "OFF" position)
	Turn ignition switch from "ACC" to "OFF" position.		Fan switch is "OFF".
	Turn ignition switch from "OFF" to "ON" position.		Apply battery voltage directly to components.
	Turn ignition switch from "ON" to "OFF" position.		Drive vehicle.
	Do not start engine, or check with engine stopped.		Disconnect battery negative cable.
	Start engine, or check with engine running.		Depress brake pedal.
	Apply parking brake.		Release brake pedal.
	Release parking brake.		Depress accelerator pedal.
	Check after engine is warmed up sufficiently.		Release accelerator pedal.
	Voltage should be measured with a voltmeter.	 <p>Pin terminal check for S.M.J. type E.C.U. and A/T control unit connectors.  <b>For details regarding the terminal arrangement, refer to the foldout page.</b></p>	
	Circuit resistance should be measured with an ohmmeter.		
	Current should be measured with an ammeter.		

# IDENTIFICATION INFORMATION

## Model Variation

Desti- nation	Body	Model			Engine	Transmission	Differential carrier
		L.H. drive		R.H. drive			
		With catalytic converter	Without catalytic converter				
Europe	Fast Back	—	—	RS13FTQ	CA18DET	FS5W71C	R200
		—	—	RS13ATQ		RE4R01A	
		RLS13FTO	—	—		FS5W71C	
		RLS13ATO	—	—		RE4R01A	
		—	RLS13FTQ	—		FS5W71C	
		—	RLS13ATQ	—		RE4R01A	
Except Europe		—		RS13FTU	FS5W71C		
		—		RS13ATU	RE4R01A		
	—	RLS13FT	—	FS5W71C			
	—	RLS13AT	—	RE4R01A			

### Prefix and suffix designations

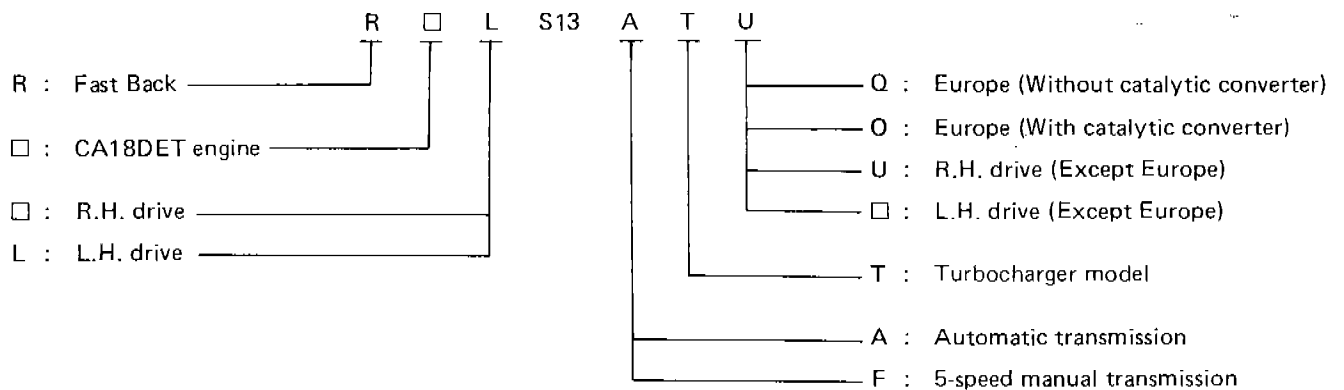

□ : means no indication.

# IDENTIFICATION INFORMATION

Key

## Identification Number

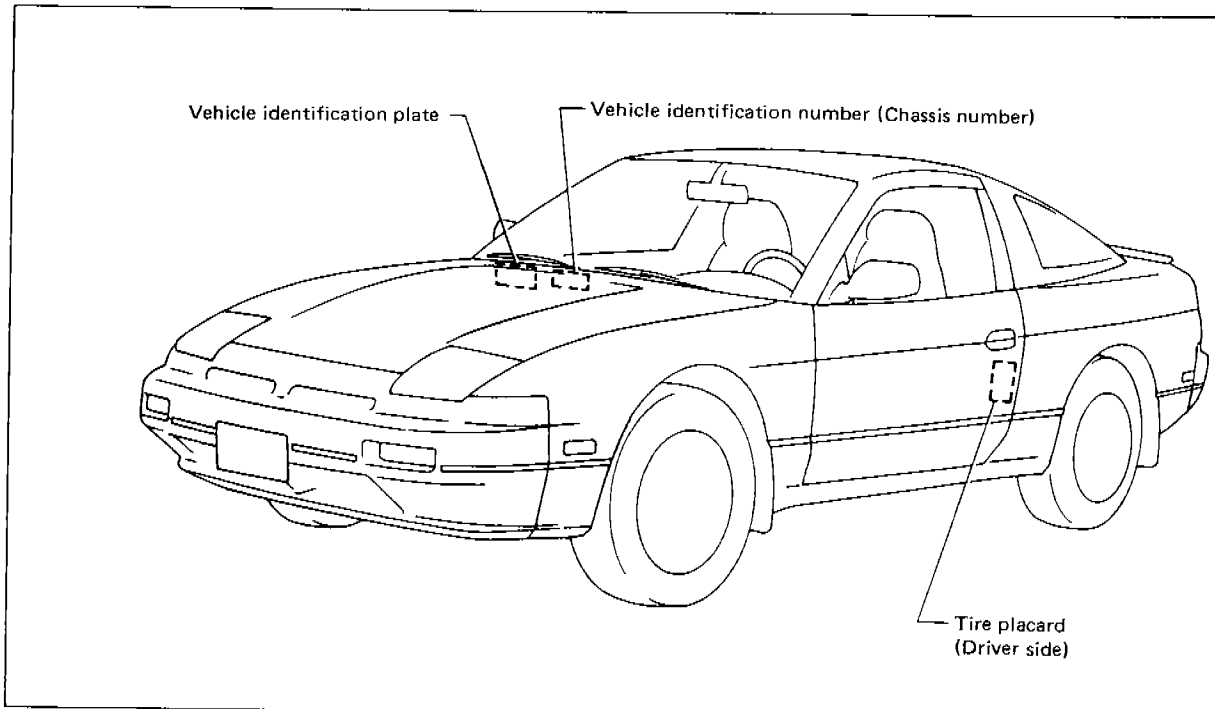

SG1554

### VEHICLE IDENTIFICATION NUMBER (Chassis number)

Prefix and suffix designations  
(For Europe)

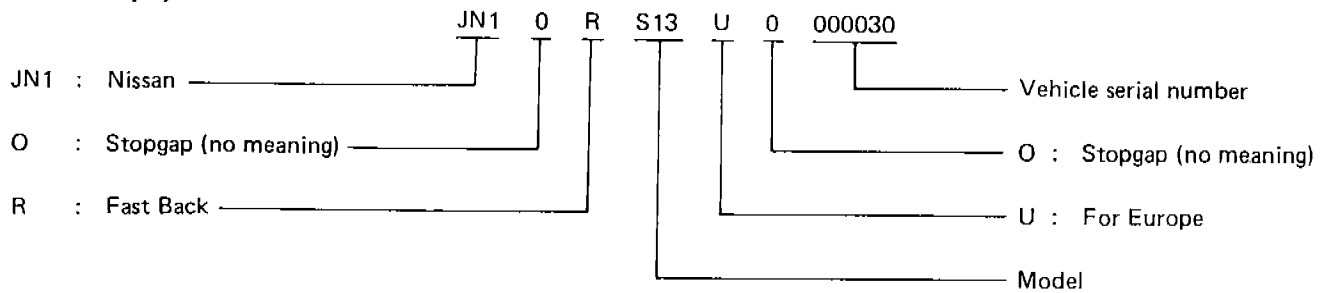

(Except for Europe)

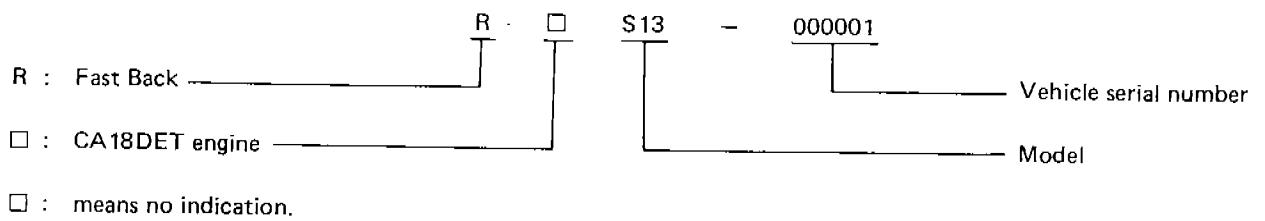

# IDENTIFICATION INFORMATION

## Identification Number (Cont'd)

### IDENTIFICATION PLATE

Europe	Except Europe	
<p style="text-align: center;">SGI025</p>	<p style="text-align: center;">SGI316</p>	<ol style="list-style-type: none"> <li>1 Type approval number</li> <li>2 Vehicle identification number (Chassis number)</li> <li>3 Gross vehicle weight</li> <li>4 Gross combination weight + Gross trailing capacity (Weight)</li> <li>5 Gross axle weight (Front)</li> <li>6 Gross axle weight (Rear)</li> <li>7 Type</li> <li>8 Body color code</li> <li>9 Trim color code</li> <li>10 Model</li> <li>11 Engine model</li> <li>12 Engine displacement</li> <li>13 Transmission model</li> <li>14 Axle model</li> </ol>

### ENGINE SERIAL NUMBER

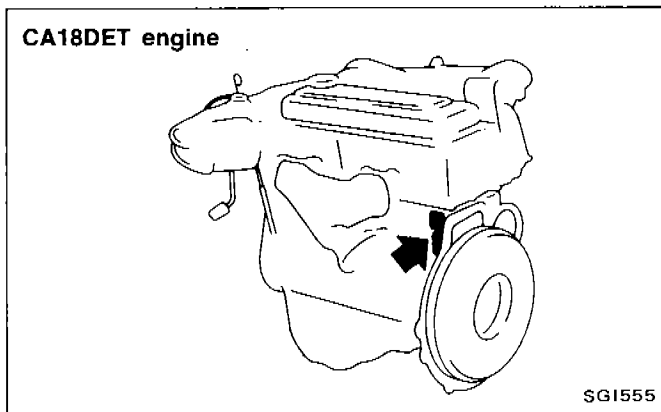

### MANUAL TRANSMISSION NUMBER

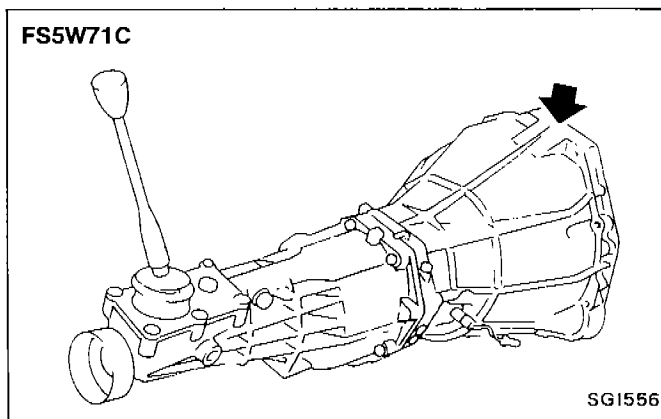

### AUTOMATIC TRANSMISSION NUMBER

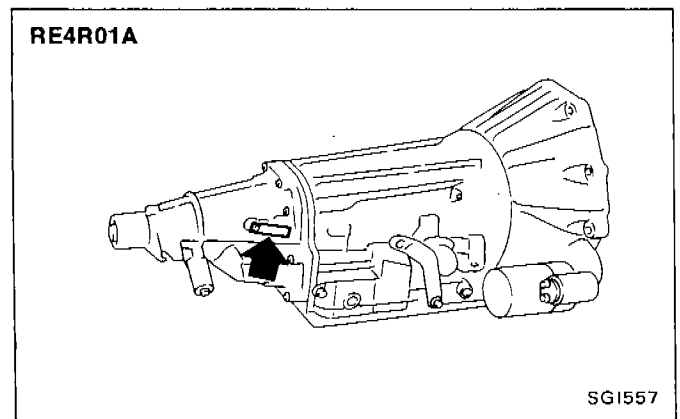



# IDENTIFICATION INFORMATION

## Dimensions

Unit: mm (in)

	Europe	Except Europe
Overall length	4,535 (178.5)	4,520 (178.0)
Overall width	1,690 (66.5)	1,690 (66.5)
Overall height	1,290 (50.8)	1,290 (50.8)
Front tread	1,465 (57.7)	1,465 (57.7)
Rear tread	1,465 (57.7)	1,460 (57.5)
Wheelbase	2,475 (97.4)	2,475 (97.4)

## Wheels and Tires

Road wheel	Steel	6-JJx15
	Aluminum	6-JJx15*1
	Offset mm (in)	40 (1.57)
Tire size	Conventional	195/60R15 86H
		195/60R15 87V*2
	Spare	T125/70D15*2

\*1: Option

\*2: Europe

## LIFTING POINTS AND TOW TRUCK TOWING

### Garage Jack and Safety Stand

#### WARNING:

- Never get under the vehicle while it is supported only by the jack. Always use safety stands to support the frame when you have to get under the vehicle.
- Place wheel chocks at the front wheels when the rear wheels are raised and place wheel chocks at the rear wheels when the front wheels are raised.

#### CAUTION:

Place a wooden or rubber block between safety stand and vehicle body when the supporting body is flat.

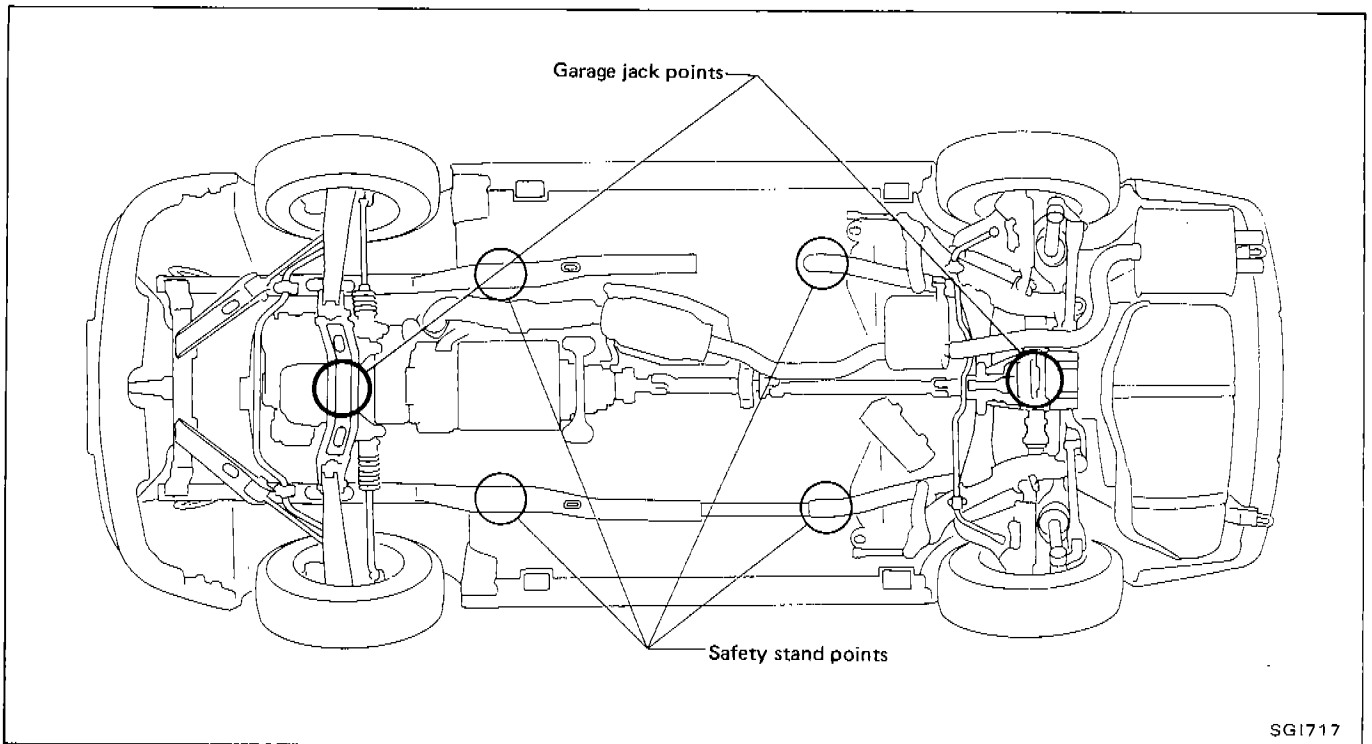

## LIFTING POINTS AND TOW TRUCK TOWING

### 2-pole Lift

#### WARNING:

When lifting the vehicle, open the lift arms as wide as possible and ensure that the front and rear of the vehicle are well balanced.

When setting the lift arm, do not allow the arm to contact the brake tubes and fuel lines.

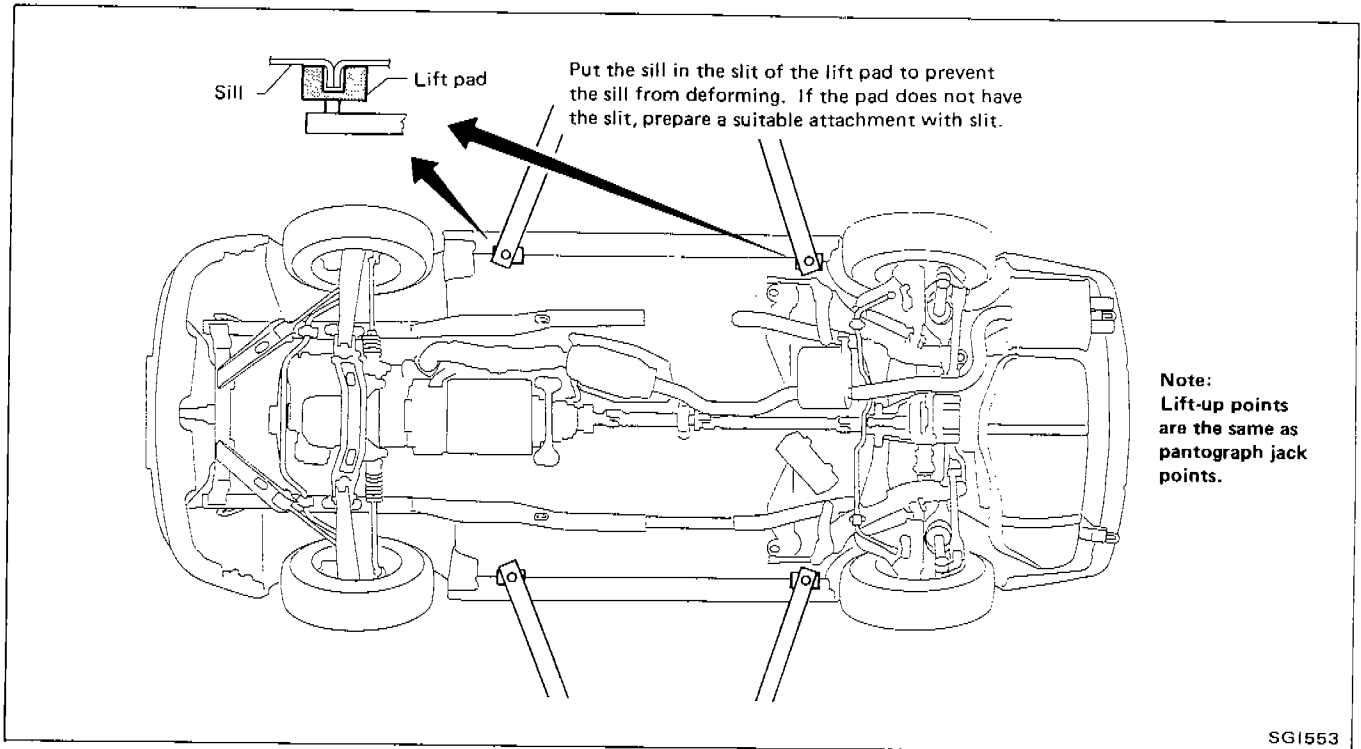

### Tow Truck Towing

#### CAUTION:

- All applicable local laws regarding the towing operation must be obeyed.
- It is necessary to use proper towing equipment to avoid possible damage to the vehicle during a towing operation.
- When towing with the rear wheels on the ground, release the parking brake and move the gearshift lever to neutral ("N" position).

NISSAN recommends that vehicle be towed with the driving (rear) wheels off the ground as illustrated.

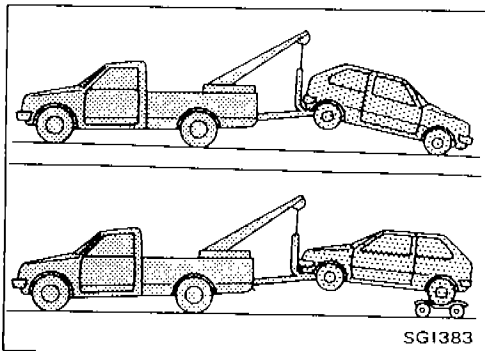

## LIFTING POINTS AND TOW TRUCK TOWING

### Tow Truck Towing (Cont'd)

#### TOWING AN AUTOMATIC TRANSMISSION MODEL WITH FOUR WHEELS ON GROUND OR TOWING WITH FRONT WHEELS RAISED (With rear wheels on ground)

Observe the following restricted towing speeds and distances.

**Speed:**

Below 50 km/h (30 MPH)

**Distance:**

Less than 65 km (40 miles)

If the speed or distance must necessarily be greater, remove the propeller shaft beforehand to prevent damage to the transmission.

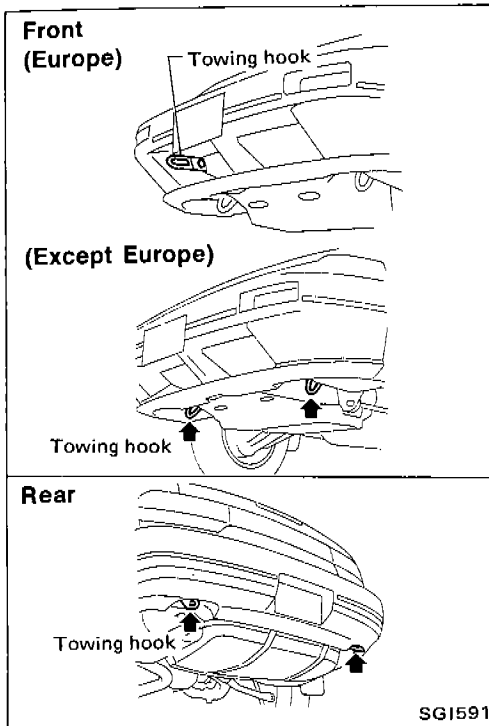

### TOWING POINT

Always pull the cable straight out from the vehicle. Never pull on the hook at a sideways angle.

# TIGHTENING TORQUE OF STANDARD BOLTS

Grade	Bolt size	Bolt diameter* mm	Pitch mm	Tightening torque (Without lubricant)					
				Hexagon head bolt			Hexagon flange bolt		
				N-m	kg-m	ft-lb	N-m	kg-m	ft-lb
4T	M6	6.0	1.0	5.1	0.52	3.8	6.1	0.62	4.5
	M8	8.0	1.25	13	1.3	9	15	1.5	11
			1.0	13	1.3	9	16	1.6	12
	M10	10.0	1.5	25	2.5	18	29	3.0	22
			1.25	25	2.6	19	30	3.1	22
	M12	12.0	1.75	42	4.3	31	51	5.2	38
1.25			46	4.7	34	56	5.7	41	
M14	14.0	1.5	74	7.5	54	88	9.0	65	
7T	M6	6.0	1.0	8.4	0.86	6.2	10	1.0	7
	M8	8.0	1.25	21	2.1	15	25	2.5	18
			1.0	22	2.2	16	26	2.7	20
	M10	10.0	1.5	41	4.2	30	48	4.9	35
			1.25	43	4.4	32	51	5.2	38
	M12	12.0	1.75	71	7.2	52	84	8.6	62
1.25			77	7.9	57	92	9.4	68	
M14	14.0	1.5	127	13.0	94	147	15.0	108	
9T	M6	6.0	1.0	12	1.2	9	15	1.5	11
	M8	8.0	1.25	29	3.0	22	35	3.6	26
			1.0	31	3.2	23	37	3.8	27
	M10	10.0	1.5	59	6.0	43	70	7.1	51
			1.25	62	6.3	46	74	7.5	54
	M12	12.0	1.75	98	10.0	72	118	12.0	87
1.25			108	11.0	80	137	14.0	101	
M14	14.0	1.5	177	18.0	130	206	21.0	152	

1. Special parts are excluded.
2. This standard is applicable to bolts having the following marks embossed on the bolt head.

\*: Nominal diameter

Grade	Mark
4T .....	4
7T .....	7
9T .....	9

